

LGM 510

Drum Seal

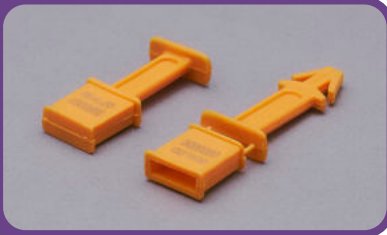

Applications

Drums, Barrels

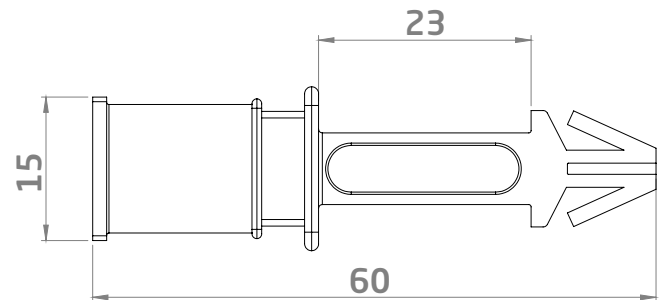

Product Description

- Made of Polystyrene (PS) body
- Special design for open top drums
- Company logo and consecutive numbering on the flag

- Laser printing option
- Pull-apart strength: 20 Kgf
- Working temperature: -20°C / +80°C

Product Description	LGM510
Quantity	1.000 pcs
Box Dimensions	23x40x15 cm
Box Weight	1,72 kg
Pallet Info	80x120x165 cm, 100.000 pcs

Color Options

Please contact our sales team for different colors



WHITE

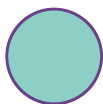

PASTEL GREEN

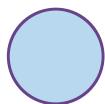

PASTEL BLUE



PASTEL RED



PASTEL YELLOW