

LGM 140

Combi Seal

Applications

Meters, Trucks, Textile, Oil Tankers

LGM140



LGM140-XL

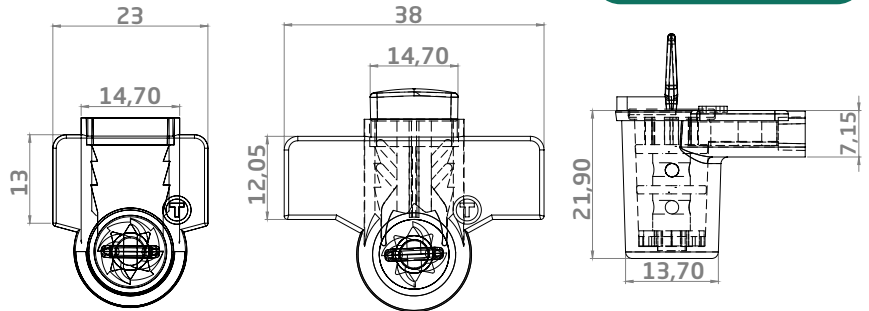

Product Description

- Made of Polycarbonate (PC) Ultra-Violet resistant body and Polyacethale (POM) colored rotor and anchor lock
- Unique design of anchor-type locking, provides enhanced security and great tamper-proof feature by blocking the colored rotor.
- Stainless steel Ø0,66mm, Galvanised Steel Ø0,66mm and PVC coated Steel Ø0,90mm sealing wire options
- Requested length of sealing wire can be attached to the Twistseal body
- Laser marking company name and serial number

- Barcode option for mobile applications (Code128, Int 2/5, etc.)
- Optional marking areas, LGM 140: 23mm and LGM 140-XL: 38mm
- Available with a white patch resistant to all solvents for best barcode contrast on transparent body.
- Complies with RoHS (Restriction of Hazardous Substances) Directive (EU) 2015/863 and its subsequent amendments
- Test reports available for ISO 4892 UV resistance
- ISO 9227 Corrosion resistance
- Pull-apart / tensile strength: 40 Kgf
- Working temperature: -40C / +120C

Product Description	LGM 140 with 25 cm wire
Quantity	1.000 pcs
Box Dimensions	23x40x22 cm
Box Weight	6,40 kg
Pallet Info	82x120x190 cm, 80.000 pcs

Color Options

Please contact our sales team for different colors

